

The Best of Both Worlds: Cloud + SASE

Prasidh Srikanth, Bitglass
Kenneth G. Hartman, SANS

June 23, 2020

SANS

from the most trusted name in information security

About Me

Kenneth G. Hartman

- BS Electrical Engineering, Michigan Technological University
- MS Information Security Engineering, SANS Technology Institute
- Multiple Security Certifications: CISSP, GIAC Security Expert, etc.
- Certified SANS Instructor – SEC545 Cloud Security Architecture & Operations

The content and opinions in this presentation are my own and do not necessarily reflect the positions, strategies, or opinions of any current or previous employer.

www.kennethghartman.com

@kennethghartman

SANS

from the most trusted name in information security

"I help my clients earn and maintain the trust of their customers"

Intrusion Pre
ndling Wireless
ols Consulting Fo
URL Filtering ES
ecurity Window
rity Firewalls Int
sion Prevent
n Intrusion Pre
ndling Wireless
IS Consulting Fo

“Identity is the
new perimeter”

???

SANS

from the most trusted name in information security

Examples of Convergence – Network Hardware

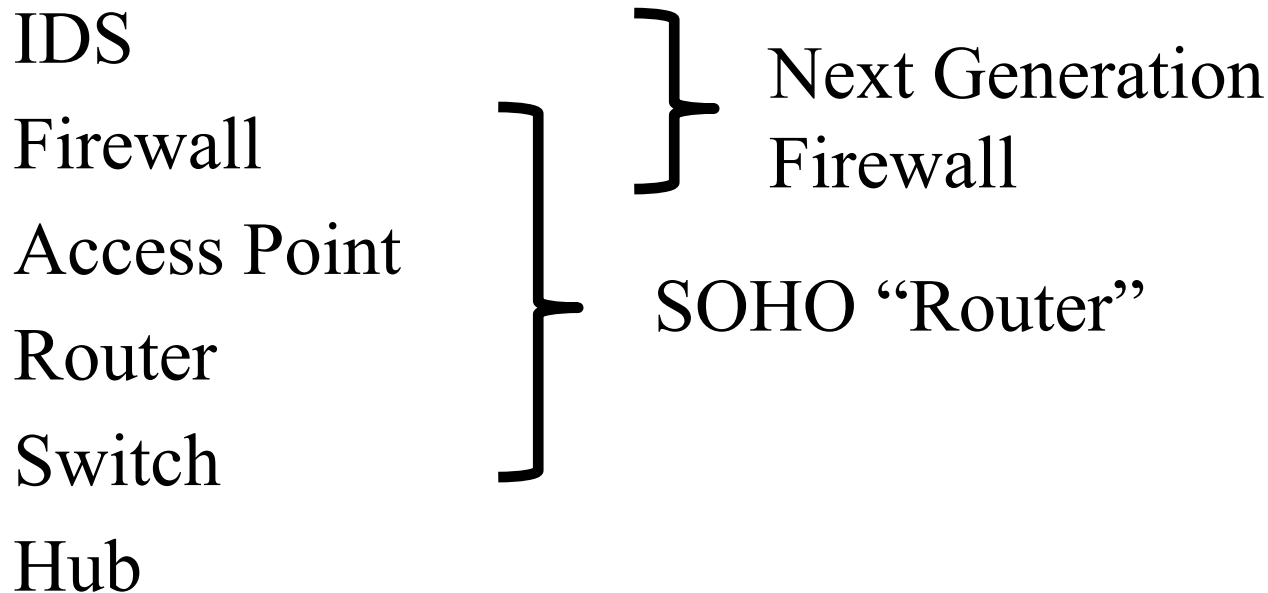

SASE Convergence

Network as a Service



Connect it



- SD-WAN
- Carriers
- CDN
- WAN Optimization
- Network as a Service
- Bandwidth Aggregators
- Networking Vendors

Network Security as a Service



Secure it

Sensitive Data Awareness

Threat Detection



- Network Security
- CASB
- Cloud SWG
- ZTNA/VPN
- WAAPaaS
- FWaaS
- DNS
- RBI

Market Convergence



Secure Access Service Edge

Gartner: *The Future of Network Security Is in the Cloud*, ID G00441737

Buzzword Bingo

CDN	FWaaS	WAF	DNS
VPN	CASB	NGFW	RBI
MPLS	IDaaS	SWG	NIDS/NIPS
SD-WAN	ZTNA	WAAPaaS	EDR

from the most trusted name in information security

SANS

Content Delivery Network (CDN)

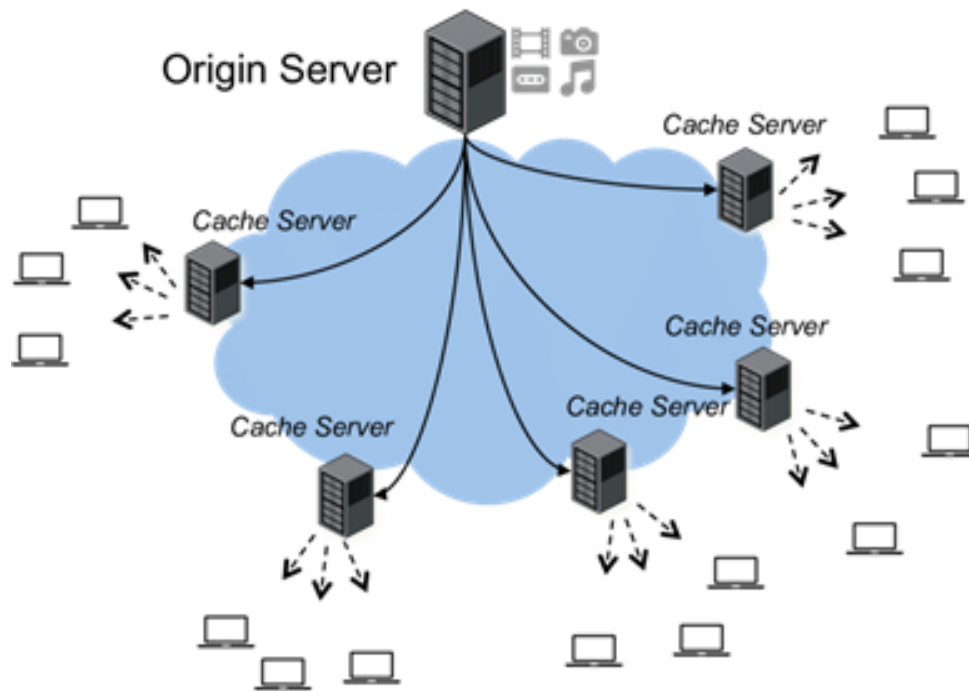

Example CDN Locations

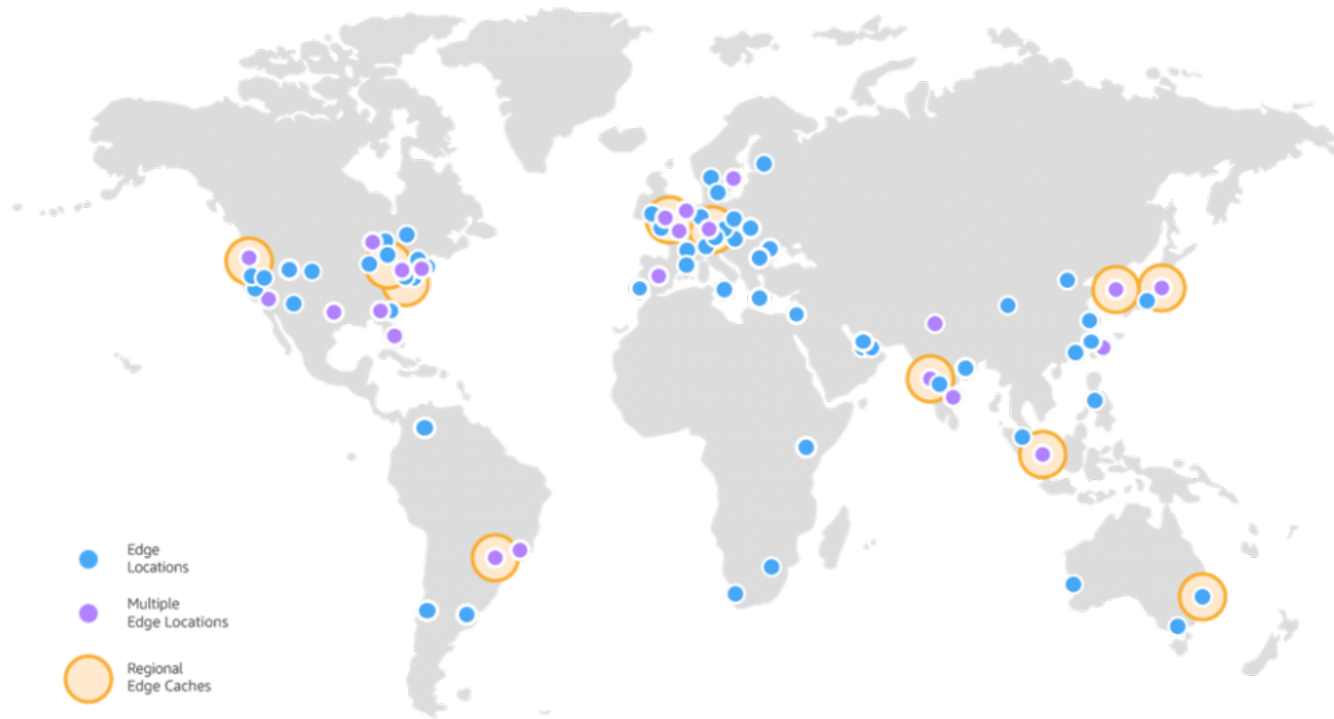

Buzzword Bingo

CDN	FWaaS	WAF	DNS
VPN	CASB	NGFW	RBI
MPLS	IDaaS	SWG	NIDS/NIPS
SD-WAN	ZTNA	WAAPaaS	EDR

from the most trusted name in information security

SANS

Cloud Access Security Broker

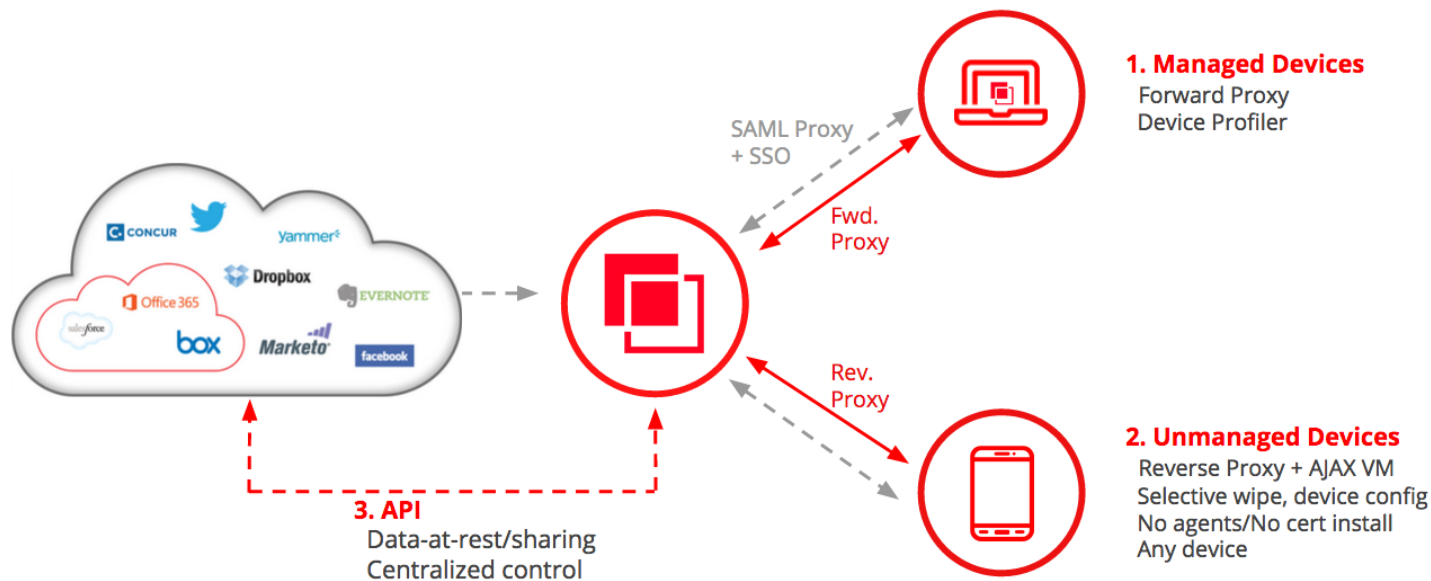

Four core features of cloud access security brokers

VISIBILITY

Shadow IT detection

Cloud services
usage tracking

Reporting and logging

Alerting



COMPLIANCE

User authentication
and authorization

Enforce regulatory
requirements



THREAT PROTECTION

User behavior
analysis

Malware
detection



DATA SECURITY

Encryption

Tokenization

Enforce data
loss prevention
policies



SANS

from the most trusted name in information security

Buzzword Bingo

CDN	FWaaS	WAF	DNS
VPN	CASB	NGFW	RBI
MPLS	IDaaS	SWG	NIDS/NIPS
SD-WAN	ZTNA	WAAPaaS	EDR

from the most trusted name in information security

SANS

Secure Web Gateway

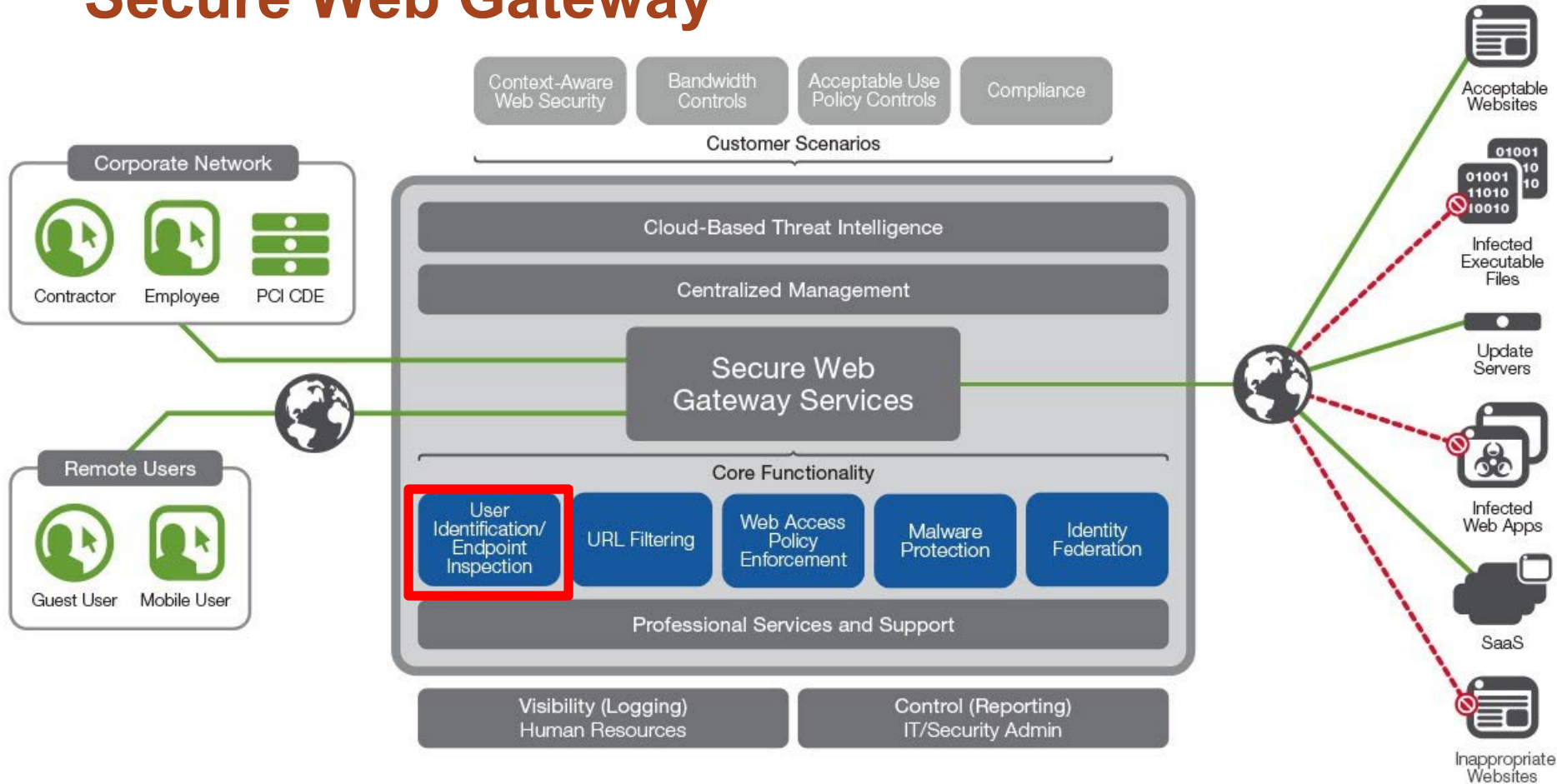

Buzzword Bingo

CDN	FWaaS	WAF	DNS
VPN	CASB	NGFW	RBI
MPLS	IDaaS	SWG	NIDS/NIPS
SD-WAN	ZTNA	WAAPaaS	EDR

from the most trusted name in information security

SANS